



威拓超声波设备

威拓—专注塑料焊接

Weituo focus on Plastic Welding

多头超声波焊接机

Multi stations ultrasonic welding machine



- 1、多组振动子多样化组合方式，前后运动采用伺服+丝杆控制，确保熔接精准，空间合理化应用。
- 2、每个焊接单元配备有位移传感器，可独立控制焊接位置深度。
- 3、超声波系统具备能量控制，具备强大的系统自我保护功能。
- 4、PLC可程式微电脑控制系统，人机界面窗口调整焊接参数。

1. Various combinations and multi-group vibration mode are adopted , servo + lead screw control is adopted for forward and backward movement, to ensure precise welding and rational application in space.
2. Each welding unit is equipped with a displacement sensor, which can independently control the welding position and depth.
3. The ultrasonic system has energy control and powerful system self-protection functions.
4. PLC programmable microcomputer control system, human-machine interface window to adjust welding parameters.

广泛应用于汽车灯罩、家电塑料零部件、汽车保险杠等。

It is Widely used in car lampshade , plastic components for household appliances, automotive bumpers, etc.

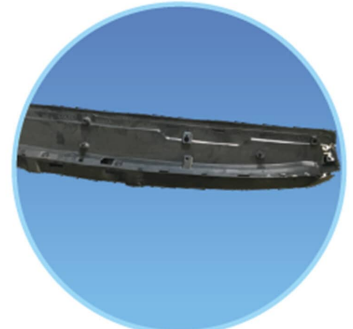

2 D 数据

2D Data

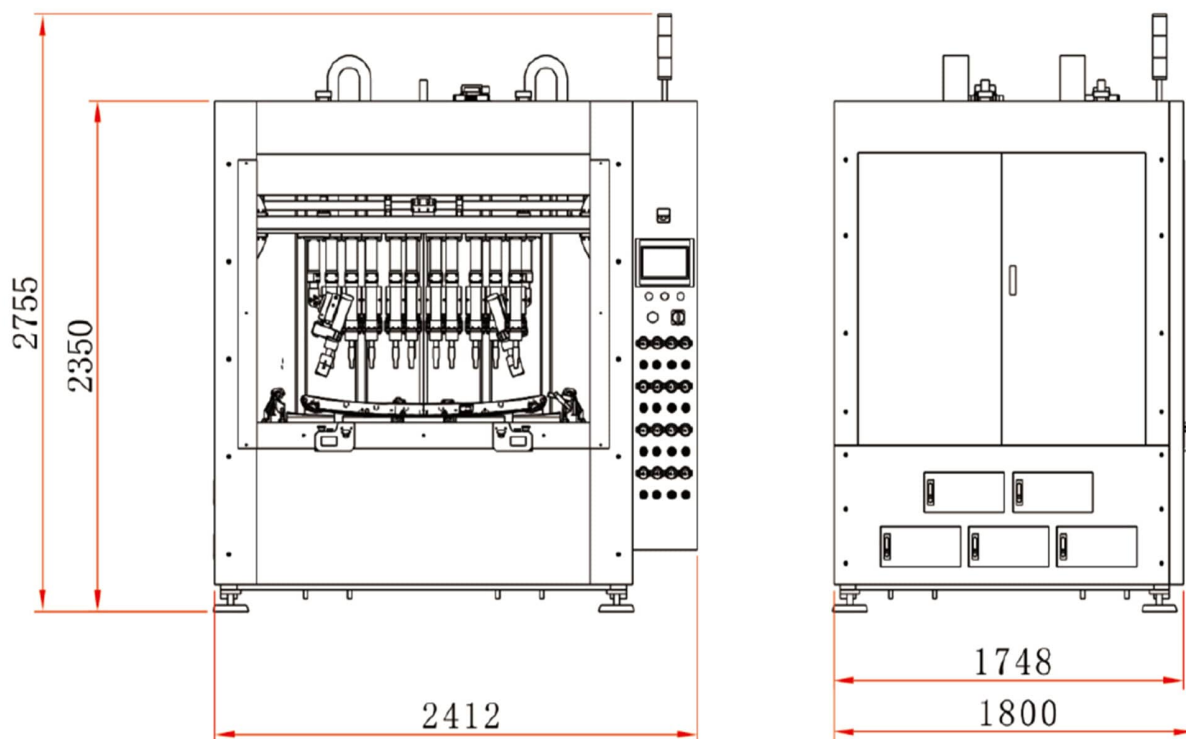

规格参数

Specification parameters

| | |
|---------------------|--|
| 机型 / Models | VW-D6800 |
| 频率 / Frequency | 28KHz 35KHz |
| 焊接时间 / Welding time | 0.01-9.99s |
| 外形尺寸 / Overall size | L2412mmxW1800mmxH1080mm |
| 重量 / Weight | 3.0T |
| 适用范围 / Applicable | 汽车内饰件、后尾翼、玩具等 |
| | automotive interior decoration, rear wing, toys, etc |

地址: 江苏省徐州市新沂市经济开发区对外贸易加工产业园4号

Address: No.2-4, Foreign Trade Processing IndustrialPark,Xinyi Economic Development Zone, Xinyi, Xuzhou, Jiangsu Province, China

销售热线: 徐总 15952283577 邮箱: 15952283577@163.com, 孙总: 18352528887 邮箱: cybhjj@163.com

Sales Hotline: Mr Xu: +8615952283577 e-mail: 15952283577@163.com, Mr Sun: +8618352528887 e-mail: cybhjj@163.com

公司网站: <http://www.js-weituo.com>, <https://shop7182961h45088.1688.com>

The company website: <http://www.js-weituo.com>, <https://shop7182961h45088.1688.com>